

Creative writing: creating your urban legend



I. Abstract 100-200

The lesson plan is aimed to develop students' narrative and descriptive skills through the topic entitled *Urban legend*. With the focus on narrative writing, students will be guided step by step to create their own urban legends and naturally get familiar with the format of the narrative writing. Meanwhile, the instruction of descriptive skills is also included in the lesson as to help students create a more vivid image of the story. Regarding the language focus, ways of depicting actions, sounds, characters and feelings are implemented via interesting games and activities, which can be further utilized by teachers in their future writing class. As this creative writing lesson had been carried out successfully by the writer and modified based on students' comments, the interesting topic and teaching material are expected to be of great use by writing teachers in high school.

II. Objectives

In an attempt to develop students' ability to narrate an event, , the lesson provides instructions toward skills of depicting actions, sounds, setting and characters necessary in narrative writing. In addition, as the material is centered on the theme "Urban legend", students will be seized by this particular form of story and thus gain inspiration toward writing their own "urban legend" by making good use of the skills learned in the writing lesson.



- Students will be able to write a narrative writing.
- Students will be familiar with organization of narrative writing.
- Students will be able to utilize descriptive skills in their writings.

III. Grade level

The lesson plan is suitable for students at intermediate proficiency level or high-intermediate level. Students already know how to use transitional words and past participle. Besides, as creative writing takes more mature skills in writing and a higher level of grammatical command, the lesson will work the best for second-year and third-year high-school students.

- Intermediate level
- High-intermediate level

IV. Time required

Three periods of class are required to accomplish the lesson; based on the sequence of difficulty, each period has a different learning focus. For the final class, it's recommended for

teachers to review the vital points of narrative writing and demonstrate wonderful student writings for students to learn from.

Time	Teaching focus	Activity
The first period	<ul style="list-style-type: none"> • What is “Urban legend”? • Descriptive skills: characters and feelings 	<ul style="list-style-type: none"> • Finding the elements in urban legend • Vocabulary game • Logical test • Homework: Making up the story
The second period	<ul style="list-style-type: none"> • Listening activity • Setting and organization of narrative writing • Descriptive skills: sounds and actions 	<ul style="list-style-type: none"> • Jigsaw picture • Sound-out clip • Story relay race
The third period	<ul style="list-style-type: none"> • Introduction of ideas and useful patterns 	<ul style="list-style-type: none"> • Writing activity: Creating your own urban legend • Peer-to-peer sharing session • Homework: A special night

V. Materials

1. PowerPoint slides
2. Handouts (See Appendix 1-3)
3. Several sets of pictures and notes
4. YouTube clips

🌱 Before the lesson



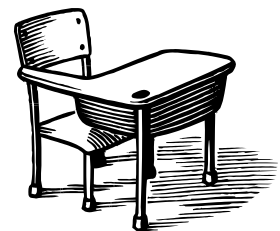

Students are already familiar with the use of present and past participle and have a command of writing basic language patterns. In the whole class activity, students are divided into a group of five.



VI. Teaching procedure

The first period



Teaching procedure	Content
<p>I. Have you heard of any “Urban legend?”</p> 	<ol style="list-style-type: none"> 1. Introduce urban legends via PowerPoint where vivid pictures and the trailer of the movie <i>Urban legend</i> are incorporated. The logic behind the story (man’s fear toward the unknown) and how the story is conveyed (from person to person) are introduced. 2. Ask students to pay attention to the specific elements exist in typical urban legends. As the clip is just movie trailer, it excludes inappropriate scenes and only provides clues about classical stories. Classical stories include “The killer in the backseat”, and “The babysitter and the man upstairs” <p>※ Clip: Urban Legend 1998 Trailer http://www.youtube.com/watch?v=ReNsIWZA89k</p> 
<p>II. Activity: Finding the elements in urban legend</p>	<ol style="list-style-type: none"> 1. After playing the clip, each group discusses and brainstorms a particular element in urban legend based on the clip and their background knowledge. Every group picks a different element. Elements include the characteristics of characters, typical settings, and the development of scary moments. 2. Ask students to share their answers group by group and show teacher’s prepared answers as supplement. Students are encouraged to have different answers. <p>※ Possible answers:</p> <p>(a) Character:</p> <ul style="list-style-type: none"> • Having a mysterious look, e.g. wearing a mask or black trench coat. • Having abnormal characteristics : lame, having obvious scar • Disguised as a clown or in the representation of a puppet <p>(b) Setting: inside the car, isolated mansion, or forest</p> <p>(c) Scary moments: scary things hiding somewhere unknown (one’s back or under the bed) suddenly pop up</p>  

III. Descriptive skills on characters and feelings: instruction and practice

1. Show Ss two YouTube clips and ask Ss to brainstorm words to describe the commercial characters inside.

※ Source of the clips:

<http://www.youtube.com/watch?v=f6OkTyI5vQA>

<http://gcaptain.com/maritime/blog/our-favorite-youtube-video-the-german-coast-guard/>

※ Brief description of the clip:

Clip One: Jing-du herbal candy

The concubine enjoys taking a bath. Most important if all, the herbal candy makes her feel like royalty.



Clip Two: The German Coast Guard

Is speaking English important to the German coast guard? The answer is positive for the guard here misinterpreted the SOS call “We are **sinking**” as “We are **thinking**.”



Q: Which of the following words could describe the characters?

in an uniform (2) with a bun(1) with a tie (2) is willing to share (1)
is open-minded (1) is on his first day (2)

3. Write Ss’ answers on the board and introduce various vocabularies on description.

※ Vocabulary

Describing character

The man in a dark cloak the man in a mask

The woman with long hair The woman with shiny necklace

The man stood with his arms crossed (Past participle)

Describing feelings

※ **Pattern: When someone V.ed, someone felt.....**

Expressions and slangs useful in describing feelings are introduced as follows.

Scared: be chilled to the bone, sit on the edge, be chicken out

Excited: be thrilled, be carried away

Angry: be like a wet hen, be pissed off, one’s face turns red

Suspicious: smell a rat, something is fishy

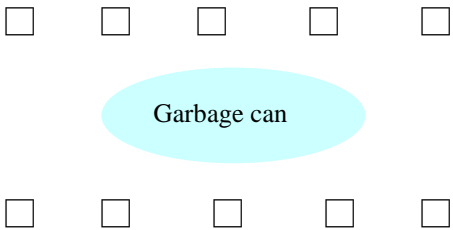

	<p>4. Vocabulary game</p> <p>For each word or phrase, the teacher reads an example sentence but muffles the word. S who can first name the word / phrase is the winner.</p> <p>“OK, students, are you ready? The first one, when I saw the movie Final Destination, I was Ding Ding to the bone and couldn’t sleep. That’s right. Adam. I was what? Yes, chilled to the bone. Good job.”</p> <p>※ Sentence:</p> <p>(a) When my mom found that I scattered my jacket and books all over on the bed, her face suddenly turned Ba Bu and asked me to clean up in one minute.</p> <p>Answer: red</p> <p>(b) When the graceful-looking lady showed up Dong a dark dress, everyone on the spot welcomed her Dong a big smile.</p> <p>Answers: in; with</p>
<p>IV. Activity:</p> <p>Logical test</p> 	<ol style="list-style-type: none"> 1. Give each group four notes, ask Ss to write down four sentences which include the description of characters or feelings. Two sentences must be correct or logical while the rest of the two must be incorrect or illogical. 2. After 5 minutes, the teacher collects the notes and mixes the notes with teachers’ prepared notes in a bag. 3. Explain the rules <ol style="list-style-type: none"> (a) Pull ten chairs and make two rows in the front of the classroom. Two rows face each other with a garbage can set between the rows. <div style="text-align: center; margin: 20px 0;">  </div> <ol style="list-style-type: none"> (b) For each round, ask 10 Ss to volunteer to play the game. The first S on each row holds a paper ball. (c) Teacher randomly picks a note and reads the sentence. If the sentence is grammatically correct or logical, the S holding the ball passes the ball to the next student. If the sentence is ungrammatical or illogical, the S throws the ball to the garbage can. The faster one is the winner and gets a point.

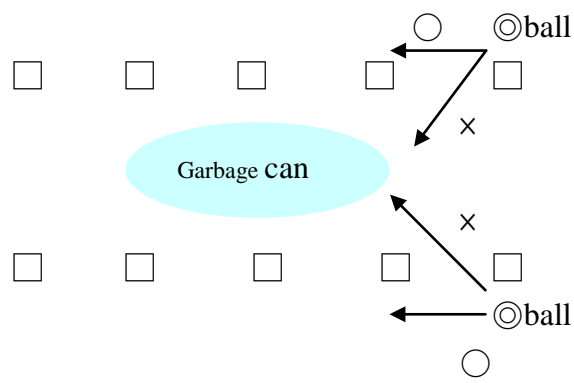

(d) If necessary, ask the S who successfully gets the point why.

✧Examples:

- (0) When John heard a woman sobbing at night, he felt curious and was ready to search the source.
- (x) As legend has it, the woman ~~in~~ long hair and big red eyes knocks on a stranger's door every night.

4. When the game is finished, go over the descriptive skills with the Ss.

V. Writing homework:
Making up the Story



1. Ask Ss to make up a story from one of the following scenarios.

(a) Basic: Babysitter and the phone call

When the babysitter was home alone with the baby, she got a phone call and in the end she shouted, "What did you say?!"

Please make up a story and include the dialogue on the phone, the caller, what the babysitter heard, and why she responded that way.

(b) Advanced: The mystery in the North Pole

In an inspection station in the North Pole, the police found the bodies of two inspectors, who were the only inspectors in that station. Mysteriously, one of them, Tom, died a month earlier than the other man named John, who died a couple of days ago. After doctor's diagnosis, the police concluded that Tom died of heart attack and John died by suicide. Besides, there was mud all over Tom's body. Everyone was confused. All the police knew was that an SOS call was sent a month ago. What happened?







✧ Note: The advanced one is a typical urban legend. It takes logical thinking to figure out the plot so that teachers could decide to include it into the practice or not. However, some students find themselves enjoy the process of thinking. One possibility of this urban legend is that John

	<p>suffered from the doubt that he might have buried Tom alive after his sudden death. Though John sent an SOS call, it took a long time for anyone to reach them. Then, without any help, he kept digging Tom’s body out to make sure and buried him again the next day. As the cycle continued for one month, he couldn’t stand the suspicion so that the story ended in tragedy. For this one, it’s up to teachers to include or not based on individual difference of students.</p> <p>2. Ask Ss to capitalize on what has learned in the lesson to complete the homework.</p>
--	--

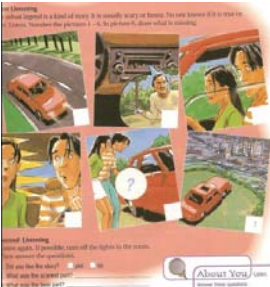
The second period



Teaching procedure	Content										
<p>I. Warm-up</p>	<ol style="list-style-type: none"> 1. Personalization: ask Ss’ experiences of being out of town 2. Forecast that the following recording is about a couple who went out of town at night while something happened. 										
<p>II. Introduce the organization of narrative writing</p> <div style="display: flex; align-items: flex-start;">  <div style="margin-left: 10px;"> <p>▲ Adopted from <i>English Firsthand 2</i></p> </div> </div>	<ol style="list-style-type: none"> 1. Distribute the page to Ss. 2. Jigsaw pictures: ask Ss to organize the pictures on the page while listening. For the recording and the page, teachers can refer to the book <i>English Firsthand 2</i>. 3. Play the recording. 4. Ask Ss to compare and discuss what they’ve heard in pairs for 2 minutes. 5. Ask Ss general questions such as “What’s the story about?” “What is the setting of the story?” “What happened to the characters?” and introduce several key vocabulary such as hook and a dangerous serial killer. 6. Instruction: introduce the concept of “setting, characters, climax and ending” in a narrative writing and explain the recording is narrated in the same logic. 7. Play the recording and ask Ss to pay attention to the organization of the story. With the headings ”setting” “characters” “climax” and “ending” provided on the handout, Ss need to jot down more detailed information. <div style="margin-top: 20px;"> <p>✧ The handout (see Appendix 1)</p> </div> <div style="margin-top: 20px;"> <table border="1" style="width: 100%; border-collapse: collapse;"> <thead> <tr> <th colspan="2" style="text-align: center;">Urban legend: the organization of the story</th> </tr> <tr> <th colspan="2" style="text-align: center;">Take notes while you listen</th> </tr> </thead> <tbody> <tr> <td style="width: 50%;">1. Setting:</td> <td style="width: 50%;">5. Key-words in the recording:</td> </tr> <tr> <td>2. Characters:</td> <td rowspan="3" style="text-align: center; vertical-align: middle;">  </td> </tr> <tr> <td>3. Climax:</td> </tr> <tr> <td>4. The end:</td> </tr> </tbody> </table> </div>	Urban legend: the organization of the story		Take notes while you listen		1. Setting:	5. Key-words in the recording:	2. Characters:		3. Climax:	4. The end:
Urban legend: the organization of the story											
Take notes while you listen											
1. Setting:	5. Key-words in the recording:										
2. Characters:											
3. Climax:											
4. The end:											

	<p>8. Play the recording again, pause at each key point, explain and check Ss' answers on the handout.</p> <p>9. Wrap up and relate this listening material to the format of narrative writing.</p>
<p>III. Descriptive skills on sounds and actions: instruction and practice</p>	<p><u>Describing sounds</u></p> <p>1. Play the sounds, ask students to name the sound and survey which sounds they consider the last thing they want to hear. Sounds can be legally downloaded from www.soundlibrary.com and Office Microsoft Clipart http://office.microsoft.com/zh-tw/clipart/default.aspx</p> <p>※ Sounds</p> <ul style="list-style-type: none"> • The sound of someone scraping one's fingernail • The sound of someone starting the engine • The sound of someone knocking on the door • The sound of footsteps • The sound of runny water • The sound of rain drops • Sighs <p>2. Introduce ways to describe the sounds centered on a different focus.</p> <p>※ Focus: A sense of quietness</p> <p>It was nothing. Only the Purr sounds made by a cat could be heard. The campus was as quiet as a tomb.</p> <p>※ Focus: fear</p> <p>The continuous sound of footsteps bothered him, disrupting his nice dream. Most important of all, his wild imagination made him quiver in bed.</p> <p>3. Ask Ss to brainstorm sounds that could be incorporated in creating different images.</p> <p><u>Describing actions</u></p> <p>1. Introduce the following verbs.</p> <p>(a) go upstairs/downstairs 上樓/下樓</p> <p>(b) start the engine 開動引擎</p> <p>(c) turn one's back 轉身</p> <p>(d) rush to... 急趕去...</p> <p>(e) press the button 按按鈕</p> <p>(f) bump into... 撞上了...</p> <p>(g) tiptoe quietly 躡手躡腳地</p>

Practice: Sound-out clip

1. Play the clip once for Ss to gain an overview.
2. Play the clip again without sound and ask Ss to describe the actions in the clip.

※ Clip: The killer in the back seat

<http://www.youtube.com/watch?v=qeNdrIEKypc>

※ The clip contains just selected scenes. With scary scenes left out, it's safe for Ss to watch.



3. After the practice, review key verbs with the Ss.

IV. Activity:
Story relay race



1. Each group picks pictures which represent character, location, object, time, action, feelings like “taking a shower” “scared”, etc.

※ Pictures and words are as follows.

- (a) Character: The babysitter, the man with a hook, the man with an ax, the woman with long black hair
- (b) Location: the chamber, school, forest, car, gas station
- (c) Object: telephone, rain, black cloak, a bloody cap
- (d) Action: drive a car, take a shower, watch TV, do homework online
- (e) Feeling: scared, with his eyes opened wide

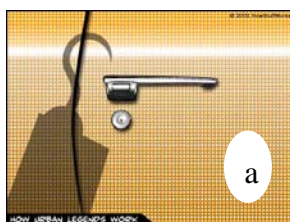

2. Give students a few pieces of papers for them to take notes.
3. Explain the rules
 - (a) As a group, students make up a story based on the pictures they pick, utilize the descriptive skills and include “characters, climax and ending” in the story.
 - (b) As the activity is entitled relay race, each member will be in charge of a part of the story in the reporting phase.



	<p>(c) Tell Ss the activity is for them to utilize the skills they've learned in the class so that they are encouraged to use as many skills as they can.</p> <p>(d) Remind Ss to use past tense and make connections in the story.</p> <p>Example 1. Group A, which got “a babysitter” “car” “listening to broadcasting” “excited ”</p>  <p>One day, a babysitter worked overtime because the parents didn't return by 11 o' clock. She felt sacred about staying alone with the baby in the house, so she decided to take the baby to her place and call the parents the next day. It was really late at the time, almost midnight. As she got in her car, the baby was extremely quiet and asleep by no reason. Somehow she felt excited about it. Maybe it's because she's such a good babysitter. While driving and dreaming about getting a raise from doing a good job, she turned on the radio, listening to broadcasting. To her surprise, she heard a strange sound coming from the backseat. Suddenly, as the radio stopped functioning, she was able to hear very clearly what the sound was like. It was someone scraping his fingernail from the backseat. For some reasons, she knew it's not the baby. Now she was reluctant to turn back...</p>
<p>V. Homework: Preparation for the writing practice</p>	<ol style="list-style-type: none"> 1. Introduce the writing practice Ss will do in the next class. 2. Give a brief description about the beginning of the story, write down the key words and ask Ss to create an image of the setting. <p>※ The brief description about the beginning of the story</p> <p>“Alright, class. Next time we will write our own urban legends. Excuse me? It's too difficult for you? No, it's not because I will give you the beginning of the story. All you have to do is to use your imagination and work on the rest of the story. Does it sound better? Wonderful! The main character is called John. He temporarily stayed in his uncle's house, which is an isolated house surrounded by a forest. One day, when he was watching TV, something went wrong...Is it scary?!! OK, that's enough for the details. Next time you will get to see the handout and for this time, I want you to draw the setting, use a color to describe it, and write a few words about it. Creating an image is very important for your success in writing next time.”</p>

	<p>※Creating the image of the setting</p> <p>(a) Draw the setting</p> <p>(b) If you can use a word/ color/ adjective to describe the setting, that will be _____.</p> <p>(c) Write a few words about the setting</p> <p>※ The handout will be distributed in the next class.</p> <div style="border: 2px dashed black; padding: 10px; margin: 10px 0;"> <p style="text-align: center;">A scary night</p> <p>One quiet night, John stayed in his uncle's place while his parents went on a trip together. Since he had nothing to do, he sat on the couch alone, surfing the channels. "What a boring day! By the way, where is Uncle George?" He mumbled. It seemed like in the house, his only accompany was the black cat kept by Uncle George. Located in the center of the village, the house is surrounded by trees and unknown plants. It was chilly all the time especially in the late night like this. As the wind blew, suddenly, John heard something...</p> </div>
--	---

The third period



Teaching procedure	Content
<p>I. Warm-up: Getting ready to write</p>	<p>1. Distribute the handout to Ss. (See Appendix2)</p> <p>2. Introduce ideas and useful patterns in writing narrative and transitional words for Ss for reference.</p> <p>※ Ideas</p> <div style="display: flex; align-items: center; margin: 10px 0;"> <div style="text-align: center; margin-right: 20px;">  </div> <div style="border: 1px dashed gray; padding: 5px;"> <p>(1) 這種文體黨考嗎? _____</p> <p>(2) 要把細節都寫進去嗎? _____</p> <p>(3) 可以加入對話或心中的聲音嗎? _____</p> <p>(4) 如何寫會比較生動有趣? _____</p> </div> </div> <p>※ Useful patterns</p> <p>說明當時發生的事</p> <div style="border: 1px solid gray; padding: 5px; margin: 5px 0;"> <p>1. As soon as S+V₂, S+V₁. 一當...就... 2. Just as S+V₂, S+V₁. 當...就...</p> <p>3. To my + N., 令我...的是</p> </div> <p>時間片語和轉承詞</p> <div style="border: 1px dashed gray; padding: 5px; margin: 5px 0;"> <p>1. 起初 at first / in the beginning 2. 一會兒過後 after a while</p> <p>3. 立刻 immediately / right away / at once 4. 最後 finally / in the end</p> </div>

<p>II. Create your own urban legend: a scary night</p>	<p>1. Distribute the worksheet to Ss. (See Appendix3)</p> <p>2. Go through the beginning of the story and brainstorm the plots with Ss.</p> <p>✧ Possible directions: an anonymous phone call, TV program, the isolated house, the mysterious uncle, the cat.</p> <p>3. While Ss are writing, go around and check if they have any difficulty in vocabulary or ideas.</p> <p>4. Encourage Ss to incorporate typical elements of urban legend and use their imagination to create their own writing pieces.</p> <p>✧ For students' work, see Appendix 4</p> 
<p>III. Peer-to-peer sharing session</p> 	<p>1. Ask Ss to form in a group of four and sit in a circle.</p> <p>2. Ss take turns to summarize their story to the rest of the group, and get oral response from their peers.</p> <p>3. After 10 minutes, ask Ss to volunteer their comments toward this writing activity.</p>
<p>IV. Homework: writing a special night</p>	<p>1. Announce homework: ask Ss to relate the skills to their personal lives and write a special night. Ss who hand in this homework can get extra credits.</p> <p>✧ Ss can choose the following topic</p> <ul style="list-style-type: none"> • The night before.../ A scary night • A sleepless night focus: actions and feelings • A night when typhoon came focus: sounds and things happened

VII. Assessment

Students will be assessed on their participation on group projects, their homework and their production of creating their own urban legends.



VIII. Suggestions

As the lesson consists of three class periods, teachers could utilize the activities or ideas in the lesson and modify based on individual needs and available time. Though the lesson is centered on the topic “Urban legend,” with a careful selection of stories and clips, the lesson could be motivating without getting students scared.

IX. References

1. Jeremy Harmer (2004). How to teach writing. Longman
2. Liz Simon (2005). Write as an expert: explicit teaching of genres. Portsmouth, NH: Heinemann.

3. Rost, Michael (2007). English Firsthand 2. Longman

4. Pictures:

<http://office.microsoft.com/zh-tw/clipart/default.aspx>,

<http://my.so-net.net.tw/scie/>,

<http://pro.corbis.com/>

4. Special thanks to all the trainers in EF teacher training program in Boston. The wonderful ideas and inspiration prompts me to finish the lesson.

Appendix 1. The note-taking form in listening activity

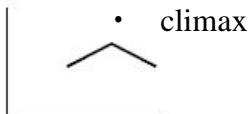
Urban legend: the organization of the story	
Take notes while you listen	
1. Setting:	5. Key words in the recording:
2. Characters:	
3. Climax:	6. 
4. The end:	

Appendix 2: Handout

Urban legend 敘述文



A. Reminders for writing narrative writing



- (1) 這種文體常考嗎? _____
- (2) 要把細節都寫進去嗎? _____
- (3) 可以加入對話或心中的聲音嗎? _____
- (4) 如何寫會比較生動有趣? _____

B. 好用句型

🌿 說明當時發生的事

- 1. As soon as S + V., S + V. 一當...,就... 2. Just as S + V., S + V. 當..., ...就...
- 3. To my + N., 令我...的是



🌿 時間片語和轉承詞

- 1. 起初 at first / in the beginning 2. 一會兒過後 after a while
- 3. 立刻 immediately / right away / at once 4. 最後 finally / in the end

Appendix 4: Students' work on "Creating your urban legend: a scary night"

A scary night written by 張斌弘

One quiet night, John stayed in his uncle's place while his parents went on a trip together. Since he had nothing to do, he sat on the couch alone, surfing the channels. "What a boring day! By the way, where is Uncle George?" He mumbled. Located in the center of the village, the house is surrounded by trees and unknown plants. It was chilly all the time especially in the late night like this. As the wind blew, suddenly, John heard something...

At first, he heard footsteps from upstairs. He wasn't sure it was his uncle or not. Then, in order to listen to the footsteps more carefully, John pressed the mute button on the remote control. As he pressed the button, the TV was suddenly off and the footsteps stopped as well. "What the hell?" John complained. "The hell..." a voice seemed to echo from upstairs. On hearing this, John trembled for a moment. "Uncle, is that you?" he shouted, but there was no answer. He gradually felt afraid while the footsteps started again from upstairs and TV was turned on by nobody. John was determined to find out who was at upstairs. He decided to take a pair of sharp scissors on the desk. As soon as he picked up the scissors with his trembling hands, the lights were all gone... The next day, the police found his body and the weapon—a pair of scissors.

A scary night (a special edition) written by 陳學穎

One quiet night, John stayed in his uncle's place while his parents went on a trip together. Since he had nothing to do, he sat on the couch alone, surfing the channels. "What a boring day! By the way, where is Uncle George?" He mumbled. Located in the center of the village, the house is surrounded by trees and unknown plants. It was chilly all the time especially in the late night like this. As the wind blew, suddenly, John heard something...

At first, there was a blackout in the house, and he wanted to find out what caused the condition. Then, when he went downstairs to the basement, he was so astounded. To his astonishment, he saw a vampire in black cloak pop up from the dark side. As soon as he saw John, he began to chase him. As John screamed and fled upstairs, the vampire bumped into a wall and fell into a trash can due to over-speeding. John couldn't help but laugh very hard. Suddenly, he had difficulty breathing. The next day, the police found his body.

Appendix 5: The PowerPoint slides

Creating your urban legend

Learning focus:

- Narrative writing
- Descriptive skills



Becky Goodwin 2014

1

Overview

- Introduce urban legend
- Finding elements in urban legend
- Descriptive skills: characters, feelings, sounds and actions
- Sound-out clip
- Homework



Becky Goodwin 2014

2

Introduce urban legend

"Have you heard of any urban legends?"



As legend has it...

- Urban legend stems from human fear.
- It's conveyed from person to person.

Becky Goodwin 2014

3

Let's take a look at the movie trailer

Hey, it's not time for movie and relaxation. Take notes on what makes urban legend scary and special.



Clip: Urban Legend 1998 Trailer <https://www.youtube.com/watch?v=7t8yW7M42>

Becky Goodwin 2014

4

Answers: finding the elements

- Characteristics of the character
- Setting
- Scary moments
- Inside a car, an isolated mansion, forest
- Scary things suddenly pop up
- Having a mysterious look



Becky Goodwin 2014

5

Descriptive skills on characters and feelings: instruction and practice

How would you describe the characters?

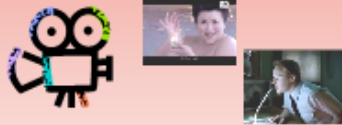

Clip: <https://www.youtube.com/watch?v=3GQ7L6n0k>
Clip: <https://www.youtube.com/watch?v=0w0k0w0k0w0k>



Becky Goodwin 2014

6

Descriptive skills on characters

Describing character

- The man in a dark cloak
the man in a mask
- The woman with long hair
- The man stood with his arms crossed
(Past participle)



Becky Goodwin 2014

7

Descriptive skills on feelings

Describing feelings

- Scared: be chilled to the bone, sit on the edge, be chicker out
- Angry: be like a wet tea, be pissed off, one's face turns red
- Suspicious: smell a rat, something is fishy

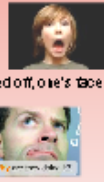

Becky Goodwin 2014

8

Descriptive skills on sounds

What is the last sound you want to hear?

- The sound of one scraping one's fingernail
- The sound of one knocking on the door
- The sound of footsteps
- The sound of runny water
- The sound of rain drops
- Sighs



Becky Goodwin 2014

9

Descriptive skills on actions

Describing actions

start the engine bump into... tum one's back rush to...

Sound-out clip

Now we will see the clip with sound-out. Use the words to describe the actions inside!

Clip: The Wer in the back seat <https://www.youtube.com/watch?v=8t8E8nc>



Becky Goodwin 2014

10

Home work: getting ready for the writing practice

To get ready for our next class, please...

(a) Draw the setting

(b) If you can use a word/ color/ adjective to describe the setting, that will be __.

(c) Write a few words about the setting



Becky Goodwin 2014

11